



Schindler 2500

Perfection means thinking beyond what's necessary. Our bed elevators show what we mean.



Func



tionality

The background of the advertisement is a blurred photograph of a hospital room. In the foreground, a portion of a hospital bed is visible, featuring a blue and white plastic frame. A red stuffed animal, possibly a teddy bear, is sitting on the bed. The background shows a window with a view of a cityscape, though the details are out of focus. The overall lighting is soft and clinical.

The Schindler 2500 is sophisticated.

To the last detail. It fulfills all the demands you could expect in hospitals, clinics, and retirement and nursing homes. An impressively functional solution.



The Schindler 2500 stands at the ready.

At all times. It lets you take the safe route.

We permanently monitor the elevator and make it available to specific persons at specific times.

A reliable thing.

Availa



bility



Precision

The Schindler 2500 is precise.

When starting and riding, and when braking and stopping. You hardly sense the comfortable movement. A persuasive performance.



You want to make the right selection. Then don't leave anything to chance.

We take it seriously

You need an efficient bed elevator? One that can withstand a lot and one that functions with absolute reliability? Then the Schindler 2500 is the right choice.

We've designed this particularly effective elevator for the comfortable transportation of patients and those in need of care. For this, it is necessary that it function with absolute precision. So that people can easily enter and exit, and arrive at their destination fast and comfortable.

Our spectrum is broad

We've designed the Schindler 2500 to handle every conceivable bed size. And to allow enough room for those accompanying them. The bed elevator also transports medical equipment in the OP area. With no jarring or shaking.

We think pragmatically

With the Schindler 2500, we rely on consistent system engineering and high standardisation. For this reason, we've given this elevator a modular construction. It is based on pre-assembled components that correspond to the latest technology. The elevator's availability is absolutely reliable. Depending upon your needs, the drive may be electromechanical or electro-hydraulic.

We guarantee it's a sure thing

We monitor the system 24 hours a day, 365 days a year. That way, problems can be corrected before they affect you.

Our elevator is available for specific purposes

With high incoming traffic, it's important to ensure the flow of traffic is as efficient as possible. This is where our registered-destination control system does the job. Together with the brand-new SchindlerID, the elevator can, if desired, be made available only to specific persons at specific times. There are practically no limits to the ways the new technology can be configured to meet your needs. It's a sophisticated system that allows the elevator to always be available to those who need it most urgently.

We keep our promises

The Schindler 2500 satisfies all important legal safety regulations and standards.

We're available everywhere

The Schindler 2500 saves you time and money. Predefined components and mandatory data make for ease of planning and short delivery times, for single or multiple systems. The Schindler 2400 and the Schindler 2600 freight elevator also belong to the same platform.

Notice

We reserve the right to make technical modifications and to alter specifications, options and colours.

All cars and options presented in this brochure are intended to serve as representations of our products. Colours and materials as shown may vary from the original.

Basic data

Load capacity	1000–4000 kg, 13–53 persons
Travel height	65 meters; max. 21 stops
Entrance	One-sided or two-sided access
Door width	900–2500 mm
Door height	2000–2400 mm
Drive	Roped or hydraulic
Speed	0.4–1.6 meters per second
Control	Collective control for groups up to four; registered-destination control
Equipment	Flexible range of equipment

What knowledge do we share with you? The realization that seconds count.

In modern hospitals, top medical specialisation is combined with individualised care. The latest discoveries of medical research are applied in everyday hospital procedures. In order for processes and workflows to be able to constantly improve, the vertical mobility also has to constantly provide better performance. We provide elevators that move more efficiently while also functioning more precisely. The Schindler 2500 is such a product. It performs its highly regarded duties every day. And every night. With absolute reliability and speed.





I have to be able to
rely on the technology.
Every time.



Expertise is one thing.
Social competence another.
For success in the health
care process, both are
needed.



Big things often start small. Take a close look at our dimensions.

Drive	Load capacity		Speed	Travel height max.		Number of stops max.		Nominal rating	Nominal current	Car			Door			Shaft	
	GQ kg	Passengers max.		VKN m/s	HQ m	ZE	* ₃ PMN kW			* ₃ INN A	* ₄ BK mm	* ₄ TK mm	* ₄ HK mm	Type	* ₅ BT mm	* ₅ HT mm	* ₆ HSG mm
Rope ^{*1}	1000	13	1.0	50	21	10.8	23	1000–1150	2000–2300	2100–2500	T2/C2	900–1000	2000–2400	1500	HK + 1500		
			1.6	65		18.9	30							1700	HK + 1650		
	1275	17	1.0	50	21	10.8	29	1100–1400	2000–2600	2100–2500	T2/C2/C4	900–1300	2000–2400	1500	HK + 1500		
			1.6	65		18.9	36							1700	HK + 1650		
	1600	21	1.0	50	21	10.8	30	1200–1700	2000–2900	2100–2500	T2/C2/C4	900–1600	2000–2400	1500	HK + 1500		
			1.6	65		22.8	43							1700	HK + 1650		
	2000	26	1.0	50	21	14.2	37	1400–2000	2000–2950	2100–2500	T2/C2/C4/C6	1000–1900	2000–2400	1500	HK + 1500		
		1.6	50		22.8	49							1700	HK + 1650			
	2500	33	1.0	50	21	25.0	43	1400–2300	2050–3500	2100–2500	T2/C2/C4/C6	1000–2200	2000–2400	1700	HK + 1700		
Hydraulic Tandem ^{*2}	2000	26	0.40/0.63	18	8	40.0	86	1550–2000	2000–2600	2100–2500	T2/C2/C4	1000–1900	2000–2400	1150	HK + 1300		
	2500	33	0.40/0.63	18	8	40.0	86	1400–2300	2050–3500	2100–2500	T2/C2/C4	1000–2200	2000–2400	1250	HK + 1300		

GQ Load capacity
VKN Speed
HQ Travel height
ZE Number of stops
PMN Nominal rating
INN Nominal current

*¹ With or without machine room
*² Machine room under, over, or to the side;
max. 10 m from shaft
*³ Maximum values

BK Car width
TK Car depth
HK Car height

*⁴ Car dimensions in 50-mm increments, the maximum allowed car area according to EN81 must be considered

T2 Telescope door, two-part
C2 Center-opening telescope door (two-part)
C4 Center-opening telescope door (four-part)
C6 Center-opening telescope door (six-part)
BT Door width
HT Door height

*⁵ Door dimensions in 100-mm increments

HSG Shaft pit depth
HSK Clear overhead below lifting beam

*⁶ Minimal values, in hydraulic variation must be increased in measure according to the configuration

Max. number of entrances: 2, opposing
Number of rides (rope): 180 per hour
Number of rides (hydraulic): 30/60 per hour
Power supply: 400 V; optional 230 V

Shaft width/depth: In the planning section on pages 20–23, ranges shown reflect typical elevator situations.

Schindler 2500 elevators are not designed for trolleys with heavy loads

Car

We construct the car according to your specifications – width, depth and height – so that your bed sizes fit perfectly. Car frames make the car extraordinarily stable.

Door

We construct the ideal door for your needs – with two, four, or six panels. They efficiently exploit the width of the shaft and, if desired, can be made exactly as high and as wide as the car. This produces a number of advantages. Guiding beds in and out is convenient. This also avoids damage to the doors. And the opening and closing speed of the doors can be adjusted.

Standards

The Schindler 2500 is certified according to the Lift Directive 95/16/EC. In addition, it fulfills all relevant standards:

- EN81-28 Remote emergency calling system for passenger and cargo elevators
- EN81-58 Fire-resistant landing doors
- EN81-70 Accessibility of passenger elevators

Environment

The Schindler 2500 meets the requirements of ISO 14001. Both the traction and the hydraulic versions display very good energy consumption values. For the hydraulic elevators, a drive system can be selected as a standard feature, which has significantly lower energy consumption when compared with conventional hydraulic aggregates.

Monitoring

The Schindler 2500 is permanently monitored from our headquarters, 24 hours a day and 365 days a year. Problems are corrected preventatively.

We trust our system. That's why we monitor it.

Traction elevator system

The Schindler 2500 can be driven electromechanically for loads of 1000 kg to 4000 kg. The traction elevator system is especially suitable for complexes with brisk traffic and where multiple elevators are used. By networking the elevators, the efficiency of transport can be increased. No machine room is necessary for up to 4.0 ton loads. That saves significant space in buildings.

Drive

The highly efficient permanent-magnet drive of the Schindler 2500 runs without gears. This provides for gains in efficiency. Because it is relatively small and functions quietly, it represents the ideal solution for machine-room-less elevators in particular. The frequency-controlled drive provides comfortable movement without vibration. The elevator achieves excellent stopping accuracy. And in addition, it is economical when it comes to energy consumption.

Control

The microprocessor control of the Schindler 2500 ideally fulfills a wide variety of tasks, for individual systems as well as for groups of up to four elevators. Standard types of controls are: Pick-up, up or down collective, or collective-selective control for groups of up to four elevators. More than 100 control options are available as standard options for individual configuration.

As option the unique Schindler Miconic 10 registered-destination control system makes a particularly significant contribution. It analyzes the transport volume of the entire system and assigns the ideal car to each passenger. The result is short waiting times and short rides.

Access control

Passenger and cargo transport can also be controlled by a key switch or card reader.

With the Miconic 10 registered destination control, our new SchindlerID technology can be applied. SchindlerID is a completely new system architecture for elevator service and access control. The passenger and cargo transportation is controlled according to demand and target group. Passengers select their destination before they enter the elevator.

The controls are built into the top floor next to the landing doors, which saves space.

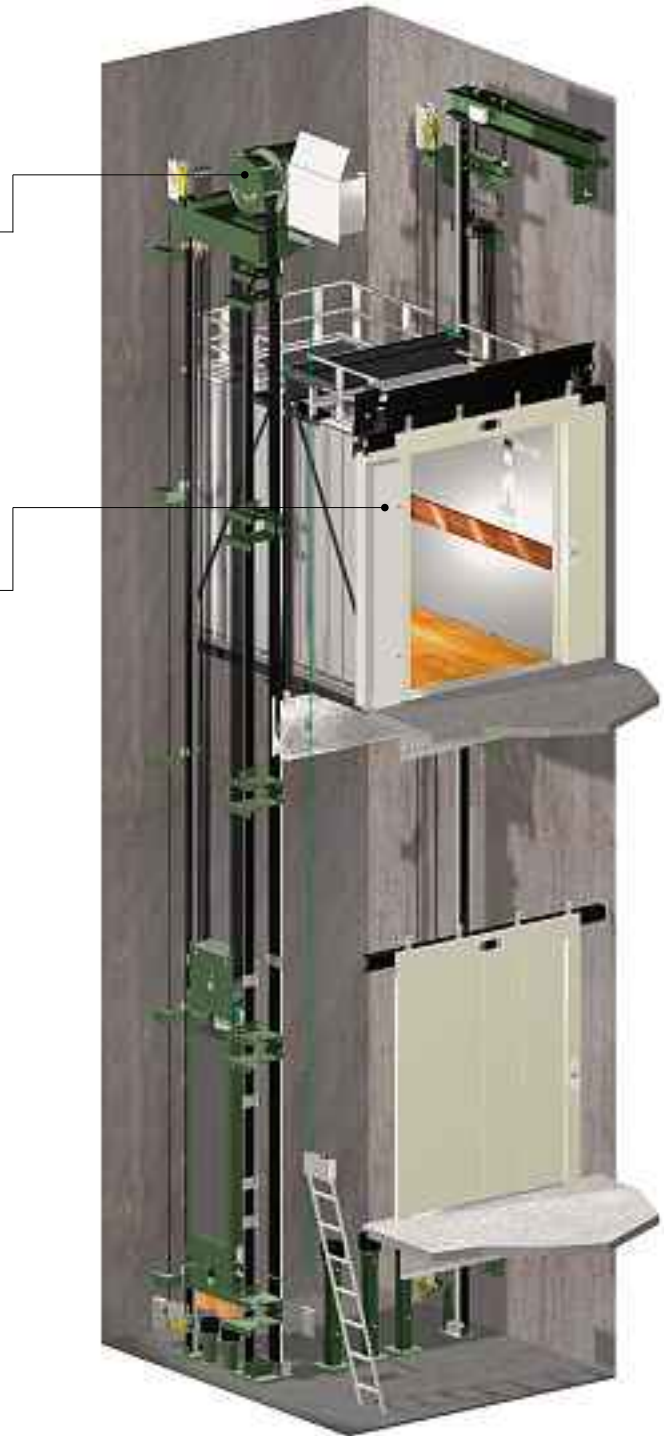

Machine-room-less traction elevator

Hydraulic elevator system

The Schindler 2500 can be driven electro-hydraulically with a load of 1000 kg to 4000 kg. This is a suitable method, particularly for single-system applications. The hydraulic elevator system offers an extraordinarily economical solution for low-rise buildings.

Drive

The Schindler 2500 possesses a unique drive system. It consists of a pump unit and an electronically controlled valve. Combined with the integrated control, it reliably fulfills high demands and provides an extraordinarily comfortable ride. The drive achieves excellent stopping accuracy.

The hydraulic version of the Schindler 2500 also displays low energy consumption. The consumption levels lie within those of the traction elevators.

Control

The specially conceived microprocessor control is suitable for a wide variety of needs and uses. It offers regulated control. This produces short ride times. You may select from the following typical control types: Pick-up, up or down collective, or collective/selective control for groups of up to four elevators. More than 100 control options are available as standard options.



Access control

The Schindler 2500 possesses access-control systems. Passenger or cargo transport can be controlled according to specific needs – such as by key switch or card reader, for example.



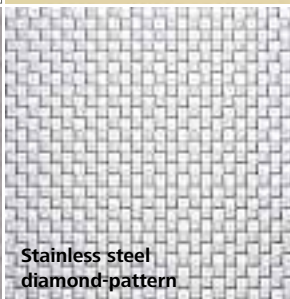

Tandem hydraulic drive

<p>Walls Car doors</p>	 <p>Skinplate/paint Catania Yellow</p>	 <p>Skinplate/paint Malmo Gray</p>	 <p>Skinplate/paint Lübeck Blue</p>	 <p>Skinplate/paint Aberdeen Green</p>
----------------------------	---	---	---	---

 <p>Stainless steel brushed</p>	 <p>Stainless steel diamond-pattern</p>	 <p>Stainless steel linen</p>		
--	---	---	--	--

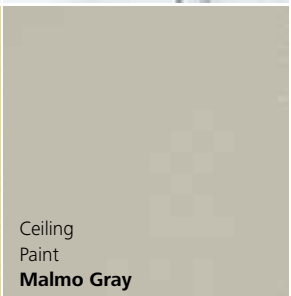
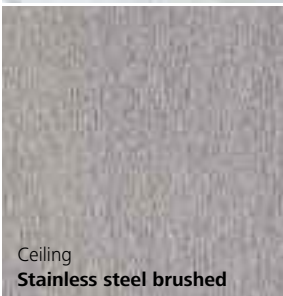

<p>Ceiling Floor</p>	 <p>Ceiling Paint Trondheim White</p>	 <p>Ceiling Paint Catania Yellow</p>	 <p>Ceiling Paint Malmo Gray</p>	 <p>Ceiling Stainless steel brushed</p>
--------------------------	---	--	---	---

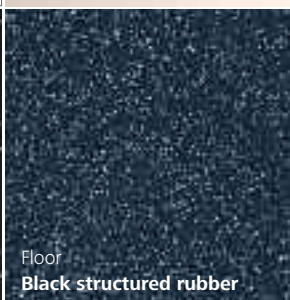
 <p>Floor Black studded rubber</p>	 <p>Floor Black structured rubber</p>	 <p>Floor Aluminium treadplate</p>		
---	---	--	--	--

We take in the most important information with our eyes. Look closely.

The medical and health care industry demands functionality, above all else. We have therefore placed great value on functionality, user-friendliness and robustness, and have designed the car's equipment to be highly durable.

You select and combine the standard materials and colours exactly as you like and need. Upon request, we can also offer other colours or materials at similar delivery and price conditions.

For car walls and doors, you can choose from the standard choices of stainless steel, paint or skinplate, in Catania Yellow, Malmö Grey, Lübeck Blue, and Aberdeen Green. Walls as well as doors may be partially or completely made of glass if desired. Landing doors are painted or are constructed from stainless steel.

Especially in the health care industry, floors must be easy-care and nonslip. The bed elevator is therefore equipped with black studded rubber flooring or with smooth PVC flooring. If desired, we can also equip your elevator with treadplate or stone flooring.

Suspended ceilings that are painted or made from brushed stainless steel provide a bright, friendly atmosphere. The indirect lighting won't blind patients.

Refined simplicity. In our accessories as well.

Car and floor button control panels

The control panels in the car of the Schindler 2500 stretch to the entire height of the car. It is installed flush with the car wall, which protects it from the damage that can occur when entering or exiting with beds. Optional handicapped-accessible button control panels for cars with voice-messaging are also available.

The car and floor-button control panels are constructed from brushed stainless steel. The button control panels in the car are also available in anthracite.

Hall control panels and floor indicators are mounted flush with the wall or into the door frame. The indicators can also be ordered with a gong sound.

Protective strips

The car is equipped with protective strips around its circumference.

They are constructed from

- black plastic,
- brushed stainless steel, or
- are specially constructed according to your wishes.

The baseboards for covering ventilation louvres in the floor are made of brushed stainless steel, and are included as standard equipment.

Thresholds

Car and landing door thresholds made of brushed stainless steel are available as an option.

Handrails

For safety, the bed elevator can be equipped with handrails. They are

- straight or
- bent, and
- are made of brushed stainless steel.

Upon request, we will install a fold-up seat in your car.

Overview of control panels



Floor level indicators
- Standard



In-car fixtures,
stretched to the entire car height
- Stainless steel
- Anthracite



Hall fixtures,
individually configurable
- 2-element
- 5-element

Schindler ID/Miconic 10



Handrail of stainless steel, curved finish



The data is available. So that you can set the standard.

Machine-room-less traction elevator with frequency-controlled drive
1000–4000 kg load capacity; 13–53 persons

Drive	Load capacity		Passengers max.	Speed	Number of entrances			Door			Shaft			
	GQ kg	VKN m/s			BK mm	TK mm	HK mm	Type	BT mm	HT mm	BS mm	TS mm	HSG mm	HSK mm
Rope	1000	13	1.0	1	1100	2100	2300	T2	900	2100	1950	2550	1500	3800
				2		2050						2910		
	1000	13	1.0	1	1300	1750	2300	T2	1100	2100	2200	2200	1500	2800
				2		1700						2310		
	1275	17	1.0	1	1200	2300	2300	T2	1100	2100	2150	2750	1500	3800
				2								2910		
	1600	21	1.0	1	1400	2400	2300	T2	1100	2100	2250	2850	1500	3800
				2										
	2000	26	1.0	1	1500	2700	2300	T2	1300	2100	2500	3150	1500	3800
				2		2650						3260		
				2		2700		C4	1500		2500	3230		
	2500	33	1.0	1	1800	2700	2300	C4	1600	2100	2950	3150	1700	4000
			2		2650						3260			
			2		2700			1800		3100	3230			

GQ Load capacity
VKN Speed
H_Q Travel height
HE_{min} Minimal interfloor distance

BK Car width
TK Car depth
HK Car height

T2 Telescope door
C4 Center-opening telescope door (four-part)
BT Door width
HT Door height

BS Shaft width
TS Shaft depth
HSG Shaft pit depth
HSK Clear overhead below lifting beam

HE_{min} = HT + 740 mm for one-sided entrances
HE_{min} = 300 mm for staggered opposite entrances

For further details, such as offers, construction plans and prices, please contact our sales department directly.

Height and plan view

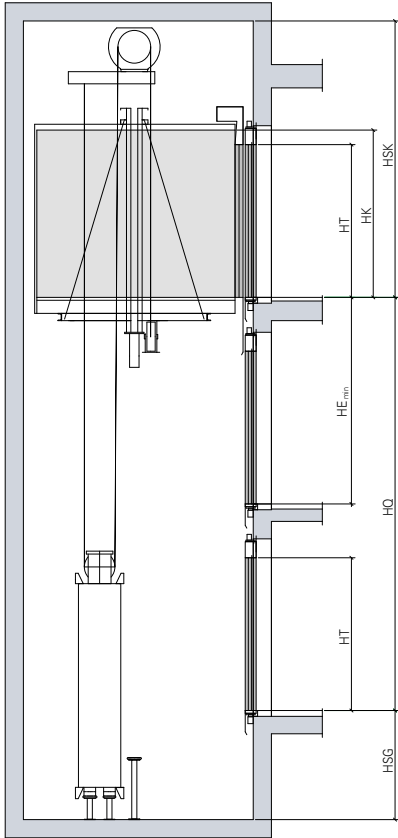

One-sided entrance

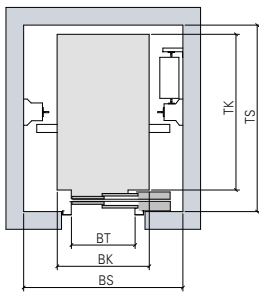

One-sided entrance
Telescopic door

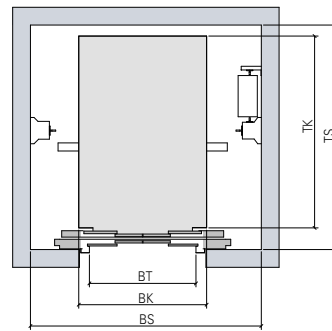

One-sided entrance
Center-opening telescopic door (four-part)

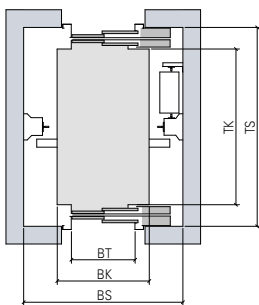

Two-sided entrance
Telescopic door

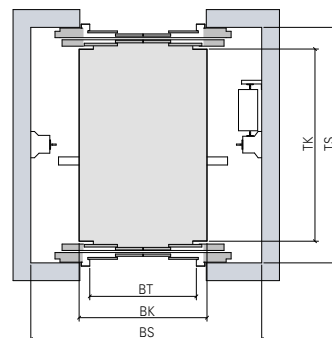

Two-sided entrance
Center-opening telescopic door (four-part)

The direct way is the quickest way. Discover it for yourself.

Hydraulic elevator with machine room
2000–4000 kg load capacity; 26–53 persons

Drive	Load capacity		Passengers max.	Speed	Number of entrances			Door			Shaft				
	GQ kg	VKN m/s			BK mm	TK mm	HK mm	Type	BT mm	HT mm	BS mm	TS mm	HSG mm	HSK mm	
Hydraulic Tandem	2000	26	0.40	1	1500	2700	2300	C4	1300	2100	2400	3150	1150	3600	
						2650									
	2500	33	0.40	1	1800	2700	2300	C4	1600	2100	2800	3150	1250	3600	
						2650									
					2		2700								
					2				1800			2950	3230		

GQ Load capacity
VKN Speed
HQ Travel height
HE_{min} Minimal interfloor distance
BO Width of machine room
TO Depth of machine room

BK Car width
TK Car depth
HK Car height

T2 Telescope door
C4 Center-opening telescope door (four-part)
BT Door width
HT Door height

BS Shaft width
TS Shaft depth
HSG Shaft pit depth
HSK Clear overhead below lifting beam

HE_{min} = HT + 740 mm for one-sided entrances
HE_{min} = 300 mm for staggered opposite entrances

For further details, such as offers, construction plans and prices, please contact our sales department directly.

Height and plan view

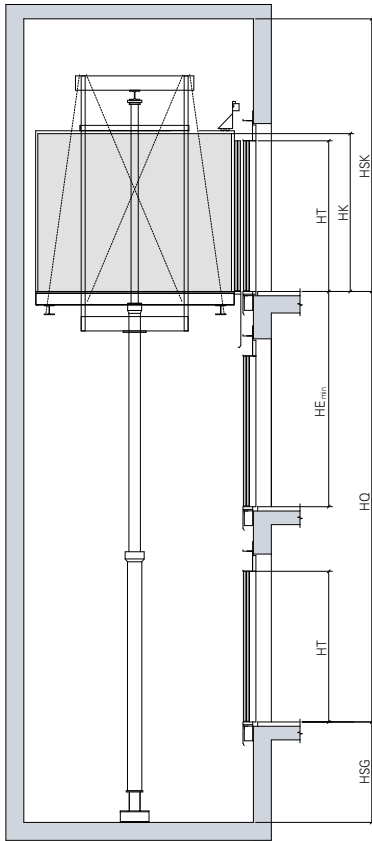

One-sided entrance
Tandem system

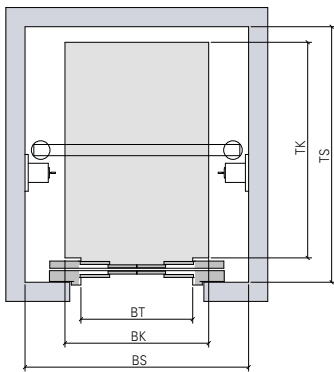

One-sided entrance
Center-opening telescopic door (four-part)

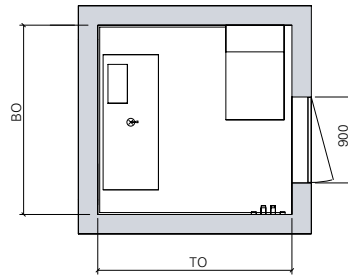

Machine room

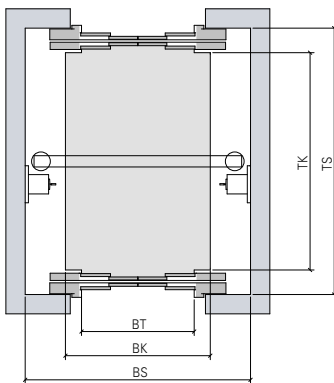

Two-sided entrance
Center-opening telescopic door (four-part)

Distance is a matter of opinion. That's why we're always nearby.

For further information including the location
of the distributor nearest you, please visit:

www.schindlerlifts.co.uk

Schindler Ltd
Benwell House
Green Street
Sunbury on Thames
Middlesex
TW16 6QT

Phone: 0044 (0) 1932 758100
Fax: 0044 (0) 1932 758258